

Kinetico 4060s OD

Non-Electric, High
Performance Combination
Softening/Filtration System



 **Kinetico**[®]
home water systems

Conditioned, Filtered Water 24 Hours a Day, Every Day

Simple, Reliable and Economical Operation

Quad Tank Design Combines Two Systems Into One

Certified Performance

Installation and Service by Trained Water Treatment Professionals

What Makes The Kineticco 4060s OD Different?

- 1. Non-Electric Operation.** Reliable. No timers or computers to set, adjust, repair or replace.
- 2. Metered, Demand Service.** Unlimited supply of clean, soft, filtered water. Eliminates guesswork, water and regenerant waste, and hard water breakthrough.
- 3. Quad Tank System.** Separate filtration and softening tanks combine two systems into one. Continuous availability of clean, filtered water. Saves money and space. Simplifies maintenance.
- 4. Overdrive Enhanced.** All tanks are in service simultaneously. Increases performance, efficiency, flow rate and media life.
- 5. High Flow Rate.** System keeps up with the conditioned water needs of today's demanding households.
- 6. Large Porting Size.** Perfectly suited for larger plumbing found in many homes. Up to 1 1/2 inch.
- 7. Efficient Hardness and Iron* Removal.** Assures consistent and continuous clean, soft, iron-free water. Saves money on soaps and cleaners. Protects plumbing and appliances.
- 8. Choice of Filtration Media:** Macrolite[®] ceramic media for removal of very fine particulate matter to protect plumbing, appliances, fixtures and clothing. Activated Carbon for dechlorination to improve taste, eliminate odors and reduce drying of hair and skin. Also filters sediment for cleaner water.
- 9. Efficient, Packed Resin Bed.** More efficient hardness removal. Conserves regenerant and water. Increases performance.
- 10. Efficient Use of Water and Regenerant.** Low water consumption. Less money spent on regenerant.
- 11. Corrosion-Resistant Valve and Tanks.** Long lasting. Can endure harsh environments.
- 12. Soft Water, Countercurrent Regeneration/Backwashing.** Increases product efficiency and water quality.
- 13. Automatic Operation.** Just add regenerant.
- 14. Outstanding Warranty.** Dependability, peace of mind.

* Iron removal capabilities are dependent on the type and concentration of iron as well as your water's other conditions.

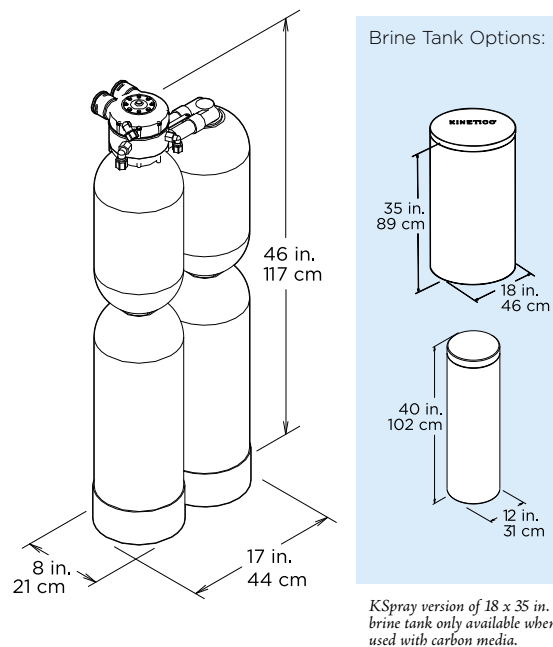

Independent Laboratory Certification

Select Kineticco products are tested and certified by Independent Laboratories such as NSF. For specific claims and certifying laboratories, refer to performance data sheets or consult your local Kineticco Dealer.

